



12-14 Setembro / **23**

São Paulo Expo - SP

MANUAL DO EXPOSITOR

1	GENERAL INFORMATION	5
1.1	ORGANIZER'S RIGHTS	1
1.2	EXHIBITOR, CONTRACTOR, AND SUPPLIER'S RESPONSIBILITIES	1
1.3	EVENT LOCATION	1
1.4	PARKING	1
1.5	EXHIBITION SCHEDULE	2
1.6	CAEX (EXHIBITOR SERVICE CENTER) – SERVICE HOURS	2
2	EXHIBITOR'S WEB PORTAL	3
2.1	MANDATORY ITEMS	3
2.1.1	MINIMUM POWER COMSUMPTION	3
2.1.2	CLEANING DURING BUILDING PERIOD	3
2.1.3	MUNICIPAL TAXES	3
2.2	ADDITIONAL SERVICES	4
2.2.1	ADDITIONAL POWER COMSUMPTION	4
2.3	HYDRAULICS	4
2.4	ACCREDITATION	4
2.4.1	EXHIBITOR'S CREDENTIALS	5
2.4.2	CONTRACTORS AND SUPPLIERS CREDENTIALS	5
2.5	PHOTOGRAPHERS AND VIDEOMAKERS	6
2.6	SECURITY CREDENTIALS	6
2.7	PAYMENTS	6
2.8	INVOICES	7
3	BUILDING AND TAKEDOWN RULES	7
3.1	GENERAL INSTRUCTIONS AND DIRECTIONS	7
3.2	LEASED AREA OCCUPANCY	11
3.3	STAND'S PROJECT SUBMISSION (SPACE ONLY)	11
3.4	HEIGHT LIMITS AND SETBACKS BUILDING FOR STANDS	13
3.5	VISIBILITY	13
3.6	DIVIDING WALLS AND FINISHING	13
3.7	GLASS WALLS	14
3.8	STAND'S FLOOR	14
3.9	PAVILION'S FLOOR	15
3.10	ALLOWED ADHESIVE TAPES	15
3.11	RAILINGS	15
3.12	BUILDING STANDS WITH A MEZZANINE FLOOR	16
3.13	AERIAL STRUCTURE	16
3.14	STAND'S HORIZONTAL PROJECTION	16
3.15	NAME BOARD PROJECTION	16
3.16	USE OF THATCH, LYCRA, AND OTHER DECORATIVE FABRICS	16
3.17	AUDITORIUM OR PROJECTION ROOMS	17
3.18	EXTERNAL LIGHTS, WALL BRACKETS, EXTERNAL SPOTLIGHTS, ETC.	17
3.19	MASONRY BUILDING	17
3.20	CABLES	17
3.21	PAVILION ELECTRICAL INSTALLATIONS	17
3.22	ELECTRICAL APPLIANCES	18
3.23	USE OF ELECTRICAL TRANSFORMERS	19
3.24	EQUIPMENT AND ENERGY TESTING	19
3.25	USE OF PPE AND CPE	19
3.26	COMMON AREAS	20
3.27	AIR CONDITIONING	20
3.28	FINAL DECORATION AND STAND'S CLEANING	20
3.29	INSTALLING RUNNER RUGS TO COMMON AREAS	20
3.30	PRODUCTS ENTRY	20
3.31	TAKEDOWN PERIOD	21
3.32	TAKEDOWN CLOSURE	21
3.33	INFORMA MARKETS AND SUSTAINABILITY	21
3.33.1	SOME IMPORTANT INFORMATION	22
3.33.2	GOOD SUSTAINABILTY PRACTICES IN EVENTS ORGANIZED AND PROMOTED BY INFORMA MARKETS	23
3.33.3	ABF SUSTAINABLE STAND AWARD	24

4	REGULATORY STANDARDS	25
4.1	NR-12 – HEALTH AND SAFETY IN MACHINERY AND EQUIPMENTS OPERATION	25
4.2	USE OF LADDERS	26
4.3	BALLOONS AND DRONES	26
5	ADDITIONAL INFORMATION	27
5.1	SECURITY AT THE PAVILION	27
5.2	MEDICAL ASSISTANCE	27
5.3	TELEPHONE AND INTERNET	27
5.4	INSURANCE	27
5.5	INTERNAL LOGISTICS SERVICE	28
5.6	CUSTOMS CLEARANCE AND FREIGHT FORWARDER	28
5.7	CO-EXHIBITORS ATTENDANCE	28
6	EXHIBITION DAYS	29
6.1	PROMOTIONAL DISTRIBUTION AND BRAND'S PROMOTION	29
6.2	DIVERSITY AND HARASSMENT	29
6.3	MACHINERY AND VEHICLES EXHIBITION INSIDE THE STAND	30
6.4	EVENTS HELD INSIDE THE STANDS	30
6.5	TICKETS	30
6.6	STAND'S SUPPLY, MAINTENANCE AND CLEANING	30
6.7	MERCHANDISING	31
6.8	COMMERCIAL REPRESENTATION	31
6.9	SOUND AND BACKGROUND MUSIC	31
6.10	PRIZES PROMOTIONAL DISTRIBUTION AND RAFFLES	32
6.11	USE OF SUBSTANCES	32
6.12	PROHIBITED ACTIVITIES	33
6.13	FIRE EXTINGUISHERS	33
6.14	COMBUSTION ENGINES	34
7	LEGAL REQUIREMENTS	34
7.1	TAX PROCEDURES	34
7.1.1	INVOICE FOR SHIPPING AND RETURN OF GOODS	34
7.1.2	SIMPLE REMITTANCE INVOICE	34
7.1.3	PRODUCTS RETURN INVOICE	35
7.2	IMPORTS	35
7.2.1	ICMS	35
7.2.2	TEMPORARY GOODS ADMISSION FOR TRADESHOWS, EXHIBITIONS, CONGRESSES AND OTHER EVENTS (FEDERAL REVENUE SERVICE)	35
7.2.3	IPI (INDUSTRIALIZED PRODUCTS TAX)	36
7.3	COVISA, ANVISA and SIF	36
7.4	MINISTRY OF WORK INSPECTION	36
7.4.1	MINISTRY OF WORK AUDITOR	36
7.5	SOCIAL SECURITY	37
ANNEX 1 – REFERENCE FOR KVA CALCULATION		37

Edition

March 2023

Dear Exhibitor,

The purpose of this manual is to guide and assist you while attending **BRAZIL WINDPOWER 2023**.

It is important that Exhibitors and Contractors be aware of the rules and deadlines required in this manual to ensure a smooth and safety exhibition.

The Exhibitor has the entire responsibility to observe and comply with all the standards required in this manual.

The organizer of this event has the right to set at any time new standards or rules that are needed to have good progress of the event, as well as change and/or add relevant information to the exhibitor, contractor, and suppliers.

We draw your attention to the standards and deadlines set in this Manual that are required by both the legislation and the authorities in order to avoid unnecessary disturbances.

For further information, Informa Markets team is at your disposal:

CUSTOMER SUCCESS

Nicolas Sacho Aga

E-mail: atendimento.bwp@informamarkets.com.br**EXHIBITOR'S WEB PORTAL**<https://portal.informamarkets.com.br/>**OPERATIONAL DEPARTMENT**

Laís Araújo

E-mail: lais.araujo@informa.com

Fernanda Oliveira

E-mail: fernanda.oliveira@informa.com

Anabela Gomes

E-mail: anabela.gomes@informa.com**CONGRESSES OPERATIONAL DEPARTMENT**

Patricia Amaral

E-mail: patricia.amaral@informa.com

Newton Dalmaso

E-mail: newton.dalmaso@informa.com

Alessandra Guerra

E-mail: alessandra.guerra@informa.com**PROJECT'S SUBMISSION - TRACK EVENTOS**

Fone: (11) 98283-1111

E-mail: projetos.canalenergia@informa.com**FINANCIAL DEPARTMENT**

Bank slips/information:

E-mail: financeirocr@informa.comInvoices- E-mail: fiscalbr@informa.com**SALES DEPARTMENT**

Adriana Guidi

E-mail: adriana.guidi@informa.com

Sergio Zacarias

E-mail: sergio.zacarias@informa.com

Camila Fernandes

E-mail: camila.fernandes@informa.com

Fabio Oddone

E-mail: fabio.oddone@informa.com

Bianca Vaz

E-mail: bianca.vaz@informa.com**MARKETING**

Thais Lemes

E-mail: thais.lemes@informa.com

Danieli Guglielmi

E-mail: danieli.guglielmi@informa.com**DigiOps – PLATAFORMA DIGITAL**

Christian Merlone

E-mail: christian.merlone@informa.com

Thais Antunes

E-mail: thais.silva@informa.com

1. GENERAL INFORMATION

1.1 ORGANIZER'S RIGHTS

The Organizer has the right to change the procedures and rules set in this manual, or even set new rules, on time, in order to ensure quality and security of any situation throughout the event.

In order to start building the stands, the Organizer requires immediate payment of any financial obligations left by the exhibitor concerning the contracted area and mandatory services or any other contracted services.

The Organizer can penalize or cease the activities in the stand that is found to be against the rules set by this manual or in the regulations stated in the exhibition contract and services.

1.2 EXHIBITOR, CONTRACTOR, AND SUPPLIER'S RESPONSIBILITIES

To respect all the rules and deadlines set in this manual and guide your employees, partners, and contracted third parties.

1.3 EVENT LOCATION

SÃO PAULO EXPO – EXHIBITION & CONVENTION CENTER

Rodovia dos Imigrantes, s/n - Km, 1,5

CEP: 04329-900

Website: www.saopauloexpo.com.br

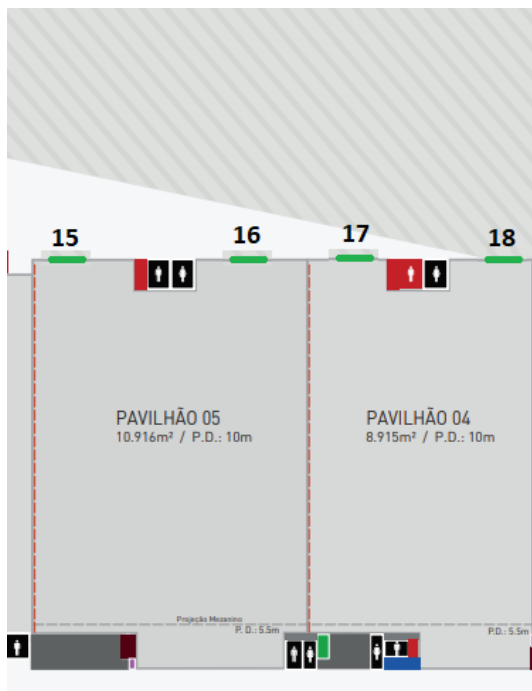

1.4 PARKING

Parking is exclusively managed by INDIGO, which is responsible for access control and billing during all the event, building, and takedown period. Some other event may occur in the complex during this period. To avoid inconvenience, we suggest carefully observing the signs at the entrances to the parking lot.

INDIGO – São Paulo Expo

☎ +55 11 5067-6790

saopaulo.spexpo@group-indigo.com

1.5 EXHIBITION SCHEDULE

	M	T	W	T	F	S	S	
SEPTEMBER					1	2	3	BUILDING
	4	5	6	7	8	9 8am – 10pm	10 8am – 10pm	DECORATION
	11 8am – 10pm	12 10am – 8pm	13 10am – 8pm	14 10am – 8pm	15 12am – 4pm	16	17	EXHIBITION DAYS
	18	19	20	21	22	23	24	TAKEDOWN
	25	26	27	28	29	30		

*September 11th – Building by 2 p.m.; decoration from 2:01 p.m. to 10 p.m.

1.6 CAEX (EXHIBITOR SERVICE CENTER) – SERVICE HOURS

	M	T	W	T	F	S	S	
SEPTEMBER					1	2	3	BUILDING
	4	5	6	7	8	9 12pm – 8pm	10 8am – 8pm	DECORATION
	11 8am – 8pm	12 8am – 8pm	13 8am – 8pm	14 8am – 8pm	15	16	17	EXHIBITION DAYS
	18	19	20	21	22	23	24	
	25	26	27	28	29	30		

2 EXHIBITOR'S WEB PORTAL

To download the exhibition documents, request additional services, consult mandatory services, schedule to pick up your credentials, fill in the credentials and register the contractor and service providers, access: <https://portal.informamarkets.com.br> using your login and password.

2.1 MANDATORY ITEMS

All the mandatory items are normally included in your participation contract.

2.1.1 MINIMUM POWER CONSUMPTION

The power consumption is measured in KVA and will be provided by the pavilion in **380v three-phase / 220v mono-phase**.

The organizer considers each kVA used throughout the exhibition days and one more day for tests on the last day of the event's building. If it is necessary to energize before this time, we kindly ask you to contact the organization to inform them about your need.

Minimum power consumption (0,1 KVA per sqm; min. 2,0 KVA): mandatory for all exhibitors for basic stand operation.

2.1.2 CLEANING DURING BUILDING PERIOD

The Cleaning Service Fee is mandatory for all exhibitors and will be charged per sqm.

This service includes the general hall cleaning (waste removal, circulation areas, restrooms, and common areas) during the building period.

The contractor must keep the stand in good clean condition for the event opening, as well as the exhibitor must keep it clean during the whole event.

This fee does not include the removal of any rubble or material during the takedown period. Exhibitors/Contractors are responsible for removing all their waste and giving the stands back in the same way they found before the building period.

2.1.3 MUNICIPAL TAXES

According to the Law No. 13.477, of DECEMBER 30, 2002, the City Hall of São Paulo of São Paulo determines to the Promoter the compulsory collection of the following tax for each stand

1. TFE - Establishment Inspection Fee;

Mandatory only to exhibitors of Fairs and Events in the City of São Paulo, the "Taxa de Fiscalização de Estabelecimento (TFE)", is due because of the performance of the competent Executive organs that exercise the police power, developing permanent activities of control, vigilance or inspection of the fulfillment of the municipal legislation. The fee is regulated by the following legislation of the city of São Paulo: Law 13.477/02 (TFE). The fee due will be collected by the Promoter and passed on to the Municipality of São Paulo, except in the occurrence of non-compliance with the norms in this manual.

2.2 ADDITIONAL SERVICES

Additional services must be hired according to the needs of each exhibitor, on the exhibitor's portal (**see all activities in the check list**).



Purchases made at CAEX during the exhibition days are subject to a minimum time of 30 minutes for service. All purchases made up to the deadline mentioned above ensure you an easier way of payment, a quick service and services availability. Anticipate your activities so as not to find lines at CAEX and allow other people to also have their services with no delays.

2.2.1 ADDITIONAL POWER CONSUMPTION

It must be requested when the consumption of kVA necessary for the operation of the equipment exceeds the mandatory minimum (consider lighting and equipment).



Remember that the voltage available in the pavilion is three-phase 380V, which can be transformed into single-phase 220V by the contractor's electrician/technician and the cost is per kVA. Any change in voltage must be provided by the contractor/exhibitor.

To calculate the number of KVA needed for your stand, the exhibitor must add up the watts of your lighting system and electrical equipment. Check the nameplate of your equipment and the reference table available in Annex 1 ("Electric Power Calculation Table") of this manual.

The KVAs used at the stand during the event will be checked and controlled by the official infrastructure company of the event. If consumption exceeds the contracted amount, the exhibitor will receive a notification and charge during the event.

2.3 HYDRAULICS

The Organizer will only provide the hydraulic point. It is the responsibility of the exhibitor/contractor to make the connection from the hydraulic point to the sink or equipment, in addition to carrying out all necessary finishing work. The hydraulic point does not come with sink and finishing.

To request this service, the stand must have a raised floor around the hydraulic point.

Water supply: ½ e ¾ inch.

Sewage removal: 40mm PVC pipe located inside the stand.

The use of a drain point for combi ovens or similar will be allowed, as long as the water temperature does not exceed 70°C to avoid deformation and leakage during its use.

ATTENTION:

For equipment that needs plumbing for water drainage, the exhibitor must request the installation of the drainage point.

The specific location of the watering point/drainage installation must be shown in the stand's project.

2.4 ACCREDITATION

Only accredited people will be allowed to enter the event areas, being mandatory to carry the credential in a visible place during the whole stay in the pavilion's internal areas.

For security reasons, when accessing the event's area, you will be asked to present a document with a photo. If someone is not carrying the documents, they will not be allowed to get in and stay in the place.

ATTENTION:

The issue of a credential 2nd copy or exchange of credentials will be charged according to the current price list.

2.4.1 EXHIBITOR'S CREDENTIALS

The credentials are personal and non-transferable, valid only for the exhibitor's employees, when correctly filled in on the Exhibitor's Web Portal. **The exhibitor is entitled by contract to 3 (three) exhibitor, 1 (one) service and 10 (ten) visitor credentials every 9m².**

For the **visitor credential (access only to visit the exhibition)** a code and link will be sent so that the exhibitor can send it to their guests to fill out the registration form and be exempted from paying for the **visitor's ticket**.

We inform you that after using the free quota, each additional credential will have a cost, according to the price list available on the Exhibitor's Web Portal.

SPONSORS

A code and link will be sent to get the **congress attendee credential (access to the exhibition + full congress)** so that the sponsor can send his or her guests to fill out the registration form and be exempt from paying for the **congress ticket**.

For sponsors, the quota will be considered according to the sponsorship category.

***To generate the credential, it is mandatory to fill in the full name, job title, and ID number (CPF or Passport). It is not allowed to insert the company's name in the fields NAME and POSITION.**

The use of these credentials by others implies their seizure. It is mandatory to present an identification document when requested.

In order to minimize losses and consequently additional costs for printing a 2nd copy of the credentials, we recommend that the exhibitor sends a duly identified carrier to CAEX from the first day of building to pick up the credentials in advance.

It is necessary for the exhibitor to present a business card or company badge to get the credentials.

It is worth mentioning that the credentials will be available to pick up only after payment of the fees.

2.4.2 CONTRACTORS AND SUPPLIERS CREDENTIALS

To request the contractor/provider credentials, it is necessary to access the provider's area, after the exhibitors register the contractor/provider. Then, they will receive an email containing the access information.

All credentials edited on the site will be picked up at the pavilion, at CAMPS - Contractor and Service Provider Service Center, from the 1st day of operation, upon payment's confirmation, project approval and correct labor documentation.

Each credential has a different cost, according to the price available on the website.

SINDIPROM MEMBERS:

Employees associated with Sindiprom will not pay for the credential, as long as they present a copy of their membership card at CAMPS - Service Center for Contractors and Service Providers.

2.5 PHOTOGRAPHERS AND VIDEOMAKERS

All photographic or filming jobs during the event should be previously requested from the event's press office, which will be informed in the list of official suppliers.

To get the credential, the professionals must present the approval received by email from the press office team.

If the contractor wants to photograph their building process, it is mandatory to present an exhibitor's authorization, valid ID with photo and make the payment of the credential at CAEX.

IMPORTANT: The professional shall photograph/film only the authorized stand. The Organizer may confiscate any unauthorized material or prevent access to the stand when the imposed limitations are not respected.

2.6 SECURITY CREDENTIALS

According to the OFFICIAL NOTIFICATION LETTER issued by FEDERAL POLICE on April 8th, 1999, the event Organizer companies are strictly forbidden to accredit people who are not qualified and regulated to the service of PRIVATE SECURITY and/or SECURITY GUARD for stands.

Both for "exhibitor's employee" and "contracted company" security, the credential will have a cost, according to the price available on the exhibitor's web portal.

We recommend you hire the Security Company which can be found in the **Official Supplier List**.

Exhibitors must hire companies legally specialized and demand the necessary documents from them, according to the Federal Police requirements like working permit, security certificate and revised working authorization, so that they are able to get their credentials.

The credential for **private security service – non-official supplier** - will be given to the Professional only after presenting the following documents at CAEX:

- ✓ Personal security documents along with regular photocopies (ID Card and Federal documents – CPF, criminal records, graduation certificate and recycling certificate for those graduated more than 2 years ago);
- ✓ Service Contract between the exhibitor and the security company or a letter written on the exhibitor's letterhead, informing the company's name and the security staff's names that will provide the service;
- ✓ Security company's cover letter written on its letterhead, informing the security staff's names who will provide the service and the exhibitor's name;
- ✓ Certificate and authorization for company operation valid through 01 year (regular photocopies).

We ask for special attention to the fulfilment of these requirements, as we will be inspected by the Federal Police during the event and, if any Law infringements are found, non-compliant companies will be subject to warning, fines and even prohibition from operating.

The Organizer will not be responsible for any theft or robbery that may occur at the event.

Under no circumstances may any security professional carry any type of weapon or firearm.



Exhibitors, contractors, or service providers will not be allowed to stay inside the pavilion during the night period. This access is only permitted for security guards, properly identified with their respective credentials and personal documents.

2.7 PAYMENTS WAYS OF PAYMENT:

A) E-commerce (by the website Electronic Manual):

- Bank Slip

Payment within 7 (seven) calendar days after purchase (respecting the deadline).

- Credit card (Amex, Visa, Mastercard and Elo).
- Purchase available on the Web Portal up to **September 1st, 2023, Business hours.**

B) CAEX (Exhibitor's Service Center, at the Exhibition Pavilion)

- Credit card (Amex, Visa, Mastercard) charged in local currency (Reais)

OBS: Payments in check are not allowed.

ATTENTION:

From September 1st, no online purchases will be allowed on the Web Portal.

In case of non-payment, after the deadline informed above, the payment must be made in the pavilion, at CAEX – Exhibitor Service Center, **no later than September 12th**, to get the credentials available and get access to the area.

At CAEX, payments can be made only on debit card and/or credit card (Amex, Visa, MasterCard and Elo).

Credentials will only be delivered upon payment of all outstanding amounts.

If you have any questions, please contact the Finance Department by email to financeirocr@informa.com.

BE AWARE OF ELECTRONIC FRAUD ATTEMPTS: NEVER ACCEPT TO EXCHANGE BANK SLIPS! Our slips are only issued by . Before scheduling the payment at the bank, confirm the bank number (033 – Santander) and the transferor code number on the slip identification line. When including the slip for payment, the corporate name INFORMA MARKETS LTDA and CNPJ 01.914.765/0001-08 must appear as beneficiary information.

2.8 INVOICES

We inform you that the 2023 invoices for the total value of the contract and services will be issued in the month in which the event is held, and for each slip, a Simple Receipt is issued with the description of the value of each item as well as the description of the withholding of taxes, as provided for in the contract. The available receipt is processed according to the advance payments inherent in the PLANNING, ORGANIZATION AND ADMINISTRATION SERVICES FOR FAIRS, EXHIBITIONS, CONGRESSES AND ALIKE - SERVICE CODE: 07161 - ITEM 17.10 OF COMPLEMENTARY LAW 116/03.

For further information about invoices and receipts, contact the Fiscal Department, by phone +55 (11) 4632-0584 or by e-mail: fiscalbr@informa.com.

3 BUILDING AND TAKEDOWN RULES

3.1 GENERAL INSTRUCTIONS AND DIRECTIONS

Dear exhibitor, thinking about the importance of choosing and hiring your contractor for the event, Informa Markets has some material with some guidelines and suggestions for this important stage for your participation.

There are several ways to get a stand for the event, either by an agency or by hiring a designer or architect to create the project and later budgeting with the contractors. Both ways have advantages and disadvantages, but the precautions are the same.

It is important to hold an internal meeting to align what is expected from the stand, what will be the strategy within your participation, what points the brand wants to highlight, what products will be exhibited, the need for buffet, watering point, storage, kitchenette, meeting room, showcases, funds, etc. Once these issues are decided, it is time to choose the contractors that will enter the competition.

Competition:

Preferably carry it out with same level companies and, if possible, that they are recommended by someone who has already worked with them. For larger stands which have greater investment, the ideal number of competitors is 3 (three).

Briefing:

It is important to provide the same briefing for all contractors and it must be as detailed as possible, so that you can get an equal comparison among budgets.

It is important to make sure and include the following information:

- Give the exhibitor's manual to the professional who will create the project, it contains important information about deadlines and building details that must be followed. Reinforce the importance of height and visibility standards.
- **It is important to read and share our material on the importance of sustainable stands – building stands that generate less waste and contribute to sustainable development.*

“Sustainable Stand” means the minimum generation of waste in building and to take down, choices focused on the lowest environmental impact, as well as stands created from sustainable materials (biodegradable/ecological/etc.) and reusable/reused (not disposable). As an example, here is a list of some items to be considered: use of LED bulbs, electricity use optimization, accessibility (access, menus, and signs in Braille), proof of correct waste management, use of certified wood (FSC), evidence of corporate socio-environmental engagement (awards, environmental management system, identification of environmental aspects) among others.

Also check the possibility of using this stand more often in your next participations in events. This action can help reduce costs and, besides that, it is good for the environment.

- Request that the stand's descriptive report be as complete as possible, covering all items and notes agreed upon to properly build the stand.
- Whenever possible, let them know about the budget available for building the stand. Based on this information, the professional in charge will be able to develop the project properly and within the budget.
- Provide as much information as possible regarding the location. It is very important to the person who is creating the project to know where the entrance, exit, restrooms, competing stands, food court are. In short, this helps the designer to explore the location as much as possible;
- Reinforce the importance of respecting the building and take down schedule, and the number of days, as well as their start and end hours, as they directly impact the type of project, logistics and the number of people on their team.
- Analyze the need for lighting and reinforce the importance of using LED lights, which reduces the cost of additional energy and contributes to the environment.

- Use legal or certified wood to build the stand, as well as carpets and other items.
- Check the mobility inside the stand so that the team and visitors can move safely and in a comfortable way.
- Request the building schedule, so that you can check if the building operation is in accordance with the necessary logistics for the event and for carrying out the decoration, entry of exhibition equipment and any operation necessary for the proper functioning of the stand during the exhibition.

The focus of the event is your product and brand, the stand is just the vehicle that will carry it, not the main thing.

Once the contractor has been chosen, it is important to visit them, get to know their structure, their warehouse, their office, and the ones responsible for the building operation.

Before signing the contract, it is important to check the supplier's CNPJ registration (Tax Number), as well as to check out their recent work and customer testimonials. It is important to learn about the company's time of activity in the market, because bad professionals sometimes open new companies when the old CNPJ is invalid.

We suggest consulting industry entities such as ABRACE (Brazilian Association of Scenography and Stands) to check if the contractor/professional is associated.

Website: <https://www.abrace.com.br/associados>

It is important that there is a clause in the contract about building delays stipulating the due fines in case of delays.

The stand must be pre-built and not completely built inside the pavilion. This action means better planning, better use of material and less waste generation during building.

Most contractors usually request 50% payment when signing the contract and the other 50% on the first day of the event, when the stands are built. We suggest leaving a small installment, about 20% to pay at least 10 days after the event, just to make sure that they will take down the stand within the schedule. The company also needs to provide support during the event, carrying out all necessary maintenance and removing all material from the stand during take down period, taking care not to damage the structure of the pavilion or generate costs that can later be passed on, and respect the event's rules.

Ask the company if they have some other clients at the event or even what jobs they are doing at the same time as your event. It is important to know which events they are working in and the amount of work they are committed to in the building, exhibition days and take down periods, as many companies do not have many employees, which means that they divide the teams into several stands and events that take place simultaneously.

Building:

Request the company to introduce the person responsible for your stand's building and always try to talk to this person, so decisions will be made faster and more effectively.

Whenever possible, visit the event during the building period, even if for a few hours. This way, you can get your credentials withdrawal in advance, purchase items that have not yet been done, such as watering points or additional energy (which ideally should be purchased in advance via e-commerce system to avoid lines at CAEX and delays in building) and check the progress of building according to the schedule.

If this is not possible, it is always important to request the person in charge of the building operation to send you photos, videos and building updates periodically. If you have any questions, please contact your Informa Markets customer service.

More complex stands require a person from your company who knows the project and can follow it from the first day of building.

Important:

The use of PPE is mandatory for all those who will be present throughout the building period, please check the requirements in the manual.

Some questions to think about:

Mezzanine floors:

From 2023 onwards, we have banned the use of mezzanine floors in our events. This decision complies with safety standards at work, the recovery of companies after the pandemic period and the lack of professionals currently working in the area, in addition to providing greater agility for the stands building and cost reduction.

Exceptions following all the conditions below may be evaluated and approved by the Organizer:

- mezzanines installed on top of containers.
- that do not require construction, only installation (without waste generation and ensuring greater safety for workers);
- and that meet the maximum height allowed in the event.

Building heights:

Stand's height: we reconsidered the height of the stands, see more information in the chapter on building standards. A tall stand does not mean that your stand will be more visible, remember the focus of the event is to show your products, services, and solutions that your company brings to the market.

Stands that are too high, besides making the project more expensive, require more time to build and make it difficult to use all the material available. In addition, they are more difficult to take down, which ends up causing the material to break in the transport and loading, as well as storing, which causes several environmental impacts. It also provides more safety for the workers, reducing risks of accidents.

The visibility of your company on these 03/04/05 days of event will depend more on what your company did in the pre-event period. This is the biggest secret of a good event that will return to your company. The stand is just a complement.

Stands with too many walls (closed stands): they make the project more expensive, and also can often make the visitor embarrassed.

Depending on the type of event and your strategy, open stands will be more attractive to your visitors, quicker to build and consequently at a lower cost. Your stand is only for 3/4 or 5 days, and you still have other expenses related to the event, therefore a practical and efficient design for doing business is much more important than a stand with a lot of walls.

Raised flooring:

It is important to check its need, as it has an extra cost to build because the water and drainage pipes, the wiring for distribution of sockets and the compressed air hoses are located under the floor.

We reinforce that if you use raised flooring, it is also mandatory to use an access ramp, that is an important accessibility for all.

There are alternatives to the use of raised flooring such as carpet or MDF board that can be installed directly on the floor. If you prefer to use them because they are less expensive, request the organization a plan that indicates the location of the watering system so that you can properly create storage and location for the equipment that need the passage of pipes, cables, and hoses.

Aerial Structure:

Structures or elements of your stand that will be hung on the pavilion's structure, if the event's pavilion allows it, are a practical solution, require less use of material to support and consequently bring greater circulation to the stand. In addition, many contractors use these points as an additional safety item in construction.

It is important to be aware of all the requirements of the pavilion regarding the necessary documentation, as well as to check out other work like this done by the contractor and make sure that they have the needed knowledge to do this type of work.

Special Lighting: it is very important and will give more life to your product and your stand.

The last item and one of the most important: hire your contractor in advance, so that they can schedule the logistics, prepare the building operation safely, build or look for parts that can be reused and hire trained teams.

The Informa Markets team will be available for further information if you need it. And also, to support you in this process.

We wish you an excellent event!

3.2 LEASED AREA OCCUPANCY

The leased areas will be available for occupation and building operations according to the dates, times, and requirements in this manual. If the areas are not occupied up to 48 hours prior to the beginning of the exhibition days they may be relocated at the sole and exclusive discretion of the Fair Management, with the exhibitor not being responsible for any refunds or claims.

IT IS MANDATORY THAT ALL STANDS HAVE CARPET, DIVIDING WALLS AND LIGHTING.

3.2.1 RESPONSIBILITY TERM AND AREA OCCUPANCY

The contractor must present the Responsibility Term, assuming responsibility for any damage that may be caused by their material and/or teams to the pavilion, to other people, including the penalties applied for non-compliance with the rules for building, maintenance, and takedown, according to deadlines established in the regulation of the fair and in this manual.

3.3 STAND'S PROJECT SUBMISSION (SPACE ONLY)

It is mandatory to present the project for any stand done according to its own building project. The construction of the stands must follow exactly the projects sent to the Organizer and any change in the project must be forwarded in advance to the Operational Department.

It is mandatory to send the following documents:

- Layout;
- Front and side elevations;

- Perspectives (1 per façade), containing the professional's legible name and signature (the person who is responsible for the project) and their phone number;
- Project and execution A.R.T. / R.R.T.*
- Electrical A.R.T. / R.R.T.;
- Photocopy of CAU/CREA card registration**
- Responsibility term duly completed and signed;
- Aerial structures: send documents directly to São Paulo Expo (form available for download on the Exhibitor's Web Portal).

Email for project's submission:

projetos.bwp@informa.com

*A.R.T. (Technical Responsibility Note) or R.R.T. (Registration of Technical Responsibility) must be signed for a Professional registered at CAU/CREA of the State of São Paulo., along with the payment proof.

**Photocopy of the professional's CAU/CREA card who signed the A.R.T./R.R.T.

For the project's analysis, the documents must be sent by the deadline stipulated by the Organizer. The construction of a stand without a project approval by the event's Operational team will not be allowed.

EXAMPLES OF PROJECTS
Layout

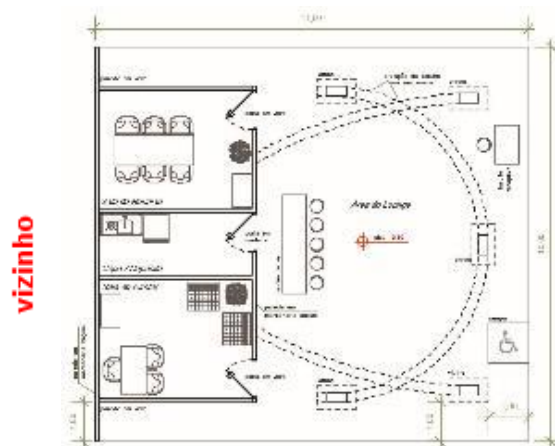

Perspectives

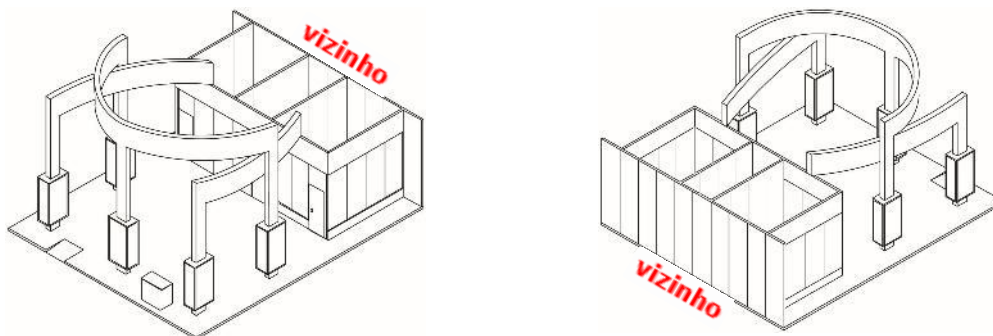

DEADLINE FOR SUBMITTING THE STANDS' PROJECTS: August 09, 2023

E-mail: projetos.bwp@informa.com

IMPORTANT NOTES:

1. All drawings must have the height and measures dimension lines of the areas;
2. It is mandatory for Contractors to identify the projects writing the Exhibitor's name, telephone number and email;
3. Non-compliance with the above requirements within the deadline exempts the Organizers from any liability and/or obligation.

ATTENTION: The stand's building operations will be allowed upon the project's approval, the payment of both exhibitor and contractor's debts. It is extremely important, for inspection reasons, to keep a copy of the project and A.R.T./R.R.T. at the stand during the entire period of building and the exhibition days.

3.4 HEIGHT LIMITS AND SETBACKS BUILDING FOR STANDS

ALTURAS (A PARTIR DO PISO DO PAVILHÃO)	RECUO MÍNIMO (somente vizinho*)
Até 3,80 m	Sem recuo
De 3,81m a 4,50m	1,00m de recuo

***O recuo é obrigatório apenas para a construção de paredes voltadas aos vizinhos (independente da configuração do estande, ex.: box, ponta de ilha e esquina).**



Altura	Recuo Mínimo
0,00m a 3,80m	0,00m
3,81m a 4,30m	1,00m

IMPORTANT:

For heights of suspended structures (aerial) please consult the Organizer. Stands with a mezzanine floor will not be allowed in 2023.

3.5 VISIBILITY

Stands are not allowed, under any circumstances, to totally block the internal view of their sides which face the pavilion's aisles. Therefore, no wall facing the aisle can have a visibility lower than 30% (percentage applied to each side) of the visual permeability. Above that, only clear glass walls, clear acrylic walls or similar material ones are allowed, since they are marked with a stripe (for security reasons), to ensure the visualization of the aisles and the neighboring stands.

3.6 DIVIDING WALLS AND FINISHING

It is mandatory to build dividing walls on the sides facing the neighbors inside your own area. The minimum height must be 2.20m, from the pavilion floor to the maximum height 4.5m, following the setback of the respective height around the perimeter of the stand.

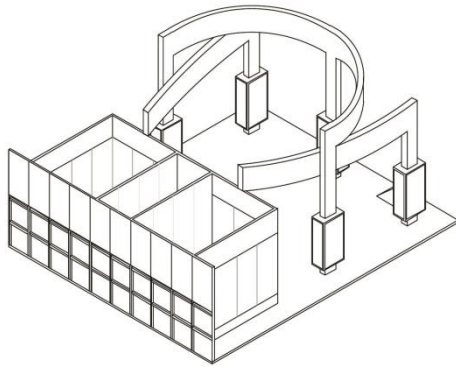
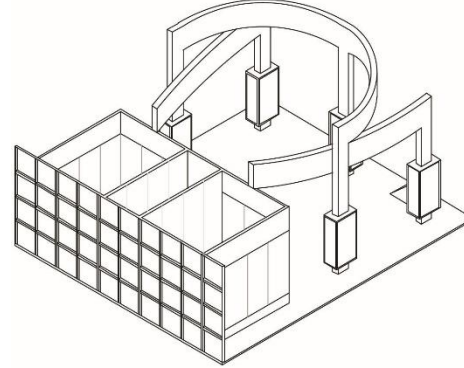
FINISHING FACING THE NEIGHBORING STAND
RIGHT

WRONG

IMPORTANT: Fire hydrants and any other firefighter equipment within the stands area must be easily accessible, visible, and well signposted.

3.7 GLASS WALLS

All glass walls should be built of tempered or laminated glass and respect the setback recommended by the Organizer.

The glass panels must be clearly identified with safety tape (stickers, graphic designs, logos, etc.) during the entire building, exhibition days and takedown period, in order to prevent accidents.

All legal requirements, Fire Service Rules, and Brazilian Standards (NBR 7199, NBR 14697 and NBR 14698, ABNT) must be obeyed. For glass panels it is mandatory to present an A.R.T. (Technical Responsibility Note) or the R.R.T (Technical Responsibility Registration), as well as the manufacture certificate (product certification).

3.8 STAND'S FLOOR

Raised flooring is optional. If there is raised flooring it is mandatory to include access for wheelchairs regardless of the stand size.

Stands with raised flooring of up to 20cm should have an access ramp with an incline between 8.33% and 10%. Ramps must have levelled sides, and the minimum allowed width is 1.20m, which allows for free passage of a 80cm wide wheelchair.

Each stand area will be marked and identified on the pavilion floor. It is the Exhibitor and/or contractor's responsibility to request assistance from the Operations Team to clear up any doubts about the leased area.

Example 1:

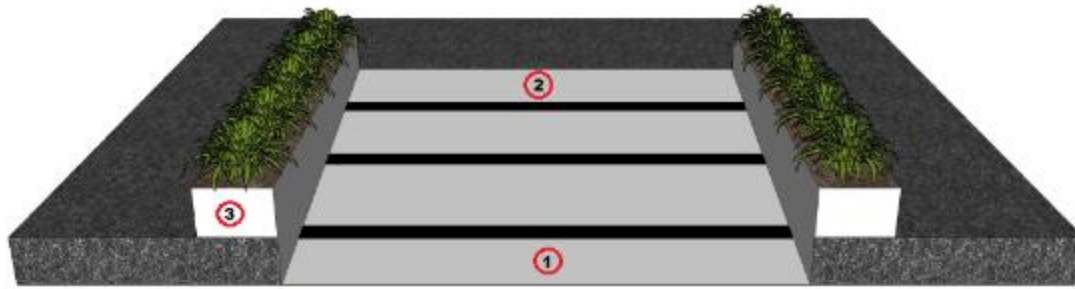

- 1 - INCLINAÇÃO ENTRE 8,33% E 10%
 2 - VÃO LIVRE DE PASSAGEM MÍNIMO 0,80m
 3 - BARREIRA LATERAL EM TODO O COMPRIMENTO DA RAMPA COM MÍNIMO DE 0,10m LARG x 0,15m ALT

Example 2:



- 1 E 2 - INCLINAÇÃO ENTRE 8,33% E 10%
 3 - VÃO LIVRE DE PASSAGEM MÍNIMO 0,80m
 4 - LARGURA MÍNIMA DA RAMPA 1,20m (VÃO + CHANFRO)

The Operational team will not be responsible for any uneven floor or any related issue which does not use raised flooring.

IMPORTANT: For all stands with raised flooring up to 0,50 cm high, from the pavilion's floor, it is mandatory to present the A.R.T. (Technical Responsibility Note) or the R.R.T (Technical Responsibility Registration) signed by a professional registered at CAU/CREA of the State of São Paulo, confirm the payment of the fees and structural calculation of the project in two copies.

3.9 PAVILION'S FLOOR

The pavilion's floor cannot be demarcated, drilled, or painted by the exhibitor/contractors. It is necessary to cover the floor using appropriate material to properly protect it.

3.10 ALLOWED ADHESIVE TAPES

When the exhibitor and/or the contractor wants to use carpet and/or lining directly on the pavilion's floor, **IT IS MANDATORY TO USE THE FOLLOWING TYPES OF EASY REMOVAL DOUBLE-SIDED TAPE:**

- Double-sided 3M SCOTCH – Ref. 4880.
- Adere Dupla Face de Papel (Adere Paper Double-sided) CARPEFIX – Ref. 462/ 40g/m² (40g/sqm).

The use of glue and/or other "sticky" abrasive derivatives directly on the floor is expressly prohibited.

3.11 RAILINGS

According to CBPMESP Technical Instruction No. 11, every ramp, stair and/or floor with a difference in level greater than 19 cm must be protected by railings to prevent falls. The height of the railings must be at least 1.10 m, the spacing between the rails cannot be greater than 20 cm.

3.12 BUILDING STANDS WITH A MEZZANINE FLOOR

The construction of a mezzanine floor will not be allowed. Following Informa Markets' new global sustainability standards, from 2023 it will not be allowed to build stands with a mezzanine floor, which reduces waste generated in construction and increases work safety.

In order to support you in the process of hiring a contractor, Informa Markets recommends hiring companies associated with ABRACE. Check it out at www.abrace.com.br/associados/

3.13 AERIAL STRUCTURE

The use of the Pavilion's airspace by any exhibitor to promote the stand is prohibited. This area may only be used by the Organizer for signage and merchandising.

The exhibitor/contractor will be allowed to place suspended structures fixed to the Pavilion's ceiling only when it is essential for the support of the stand, provided that the following documentation mentioned in the file **Norms Aerial Structure SÃO PAULO EXPO -EXHIBITION & CONVENTION CENTER** is presented to the operational team from SÃO PAULO EXPO -EXHIBITION & CONVENTION CENTER up to 30 (thirty) days before the event.

- **The amount charged is per point attached to the metallic structure of the pavilion.**
- **The maximum load capacity is 50kg per attached point.**

Download the file (Aerial Structure Standards SÃO PAULO EXPO -EXHIBITION & CONVENTION CENTER) on the Exhibitor's Web Portal. It describes the procedures and standards for the aerial structure in the pavilion.

São Paulo Expo



(11) 5067-1717

riggingspexpo@glbr.com.br

3.14 STAND'S HORIZONTAL PROJECTION

The horizontal projection of any construction element or displayed products must necessarily be within the leased area.

No projections on neighboring stands or on the aisles will be permitted.

3.15 NAME BOARD PROJECTION

Elevated fronting installations that are projected outside the limits of the area will not be allowed, except for lighting spots, and only if they are at a minimum height greater than 2.80 m.

The stands' identification can only be done on the sides facing the streets. Name boards facing stand's neighbors will not be allowed.

3.16 USE OF THATCH, LYCRA, AND OTHER DECORATIVE FABRICS

Thatch, lycra and decorative fabrics must present a certificate of fire-retardant products application. These materials must mandatorily be accompanied by the appropriate number of fire extinguishers, as defined by the Organizer and/or the official fire brigade.

Anti-flame tests will be carried out on this material and there will be a specific time to get them to enter the place.

The report, the receipt, and the A.R.T./R.R.T. application of the anti-flame product must be handed over to the event's fire brigade during the building period.

3.17 AUDITORIUM OR PROJECTION ROOMS

In enclosed areas such as auditoriums, projection rooms, and other closed or dark spaces, emergency lights must be included as well as acoustics related to the activity, emergency exits and maximum permitted capacity signs, and any other necessary safety equipment.

The Organizer may require installation of additional safety equipment, and block access to any room that does not comply with any one of these mandatory safety items.

3.18 EXTERNAL LIGHTS, WALL BRACKETS, EXTERNAL SPOTLIGHTS, ETC.

All external lights must be protected, preventing peoples' access. Wall brackets or spotlights must be above 2.80m high or must be isolated and protected from visitors' access.

All stand's lights must be self-sufficient: neither the exhibitor nor the contractor should rely on the place's general lighting. The Exhibitor/contractor must set the lights in order not to affect neighboring stands (spotlights, etc.), or visitors.

The Organizer reserves the right to block access to the stand until requests for protection or total equipment removal have been complied with.

3.19 MASONRY BUILDING

When a masonry construction is essential, it is required to be approved by the Organizer before starting the stand's project. If it is approved, the stand's floor must be covered before its construction, using proper material suitable for its protection.

3.20 CABLES

The use of cables or any connection elements that cut streets, common areas or neighboring stands is not allowed. If it is needed, it must be anticipated and discussed with the Organizer.

It is mandatory to use a flame-resistant cable with double mechanical isolation (PP type). In case of doubt, refer to NBR 5410. Every stand must be grounded.

3.21 PAVILION ELECTRICAL INSTALLATIONS

To increase safety in the execution of electrical installations and maintain compliance with rules in force, the power cables used to supply electricity to the stands and other needs for events held in the pavilions of São Paulo Expo will have a Female Plug from PCE brand.

PCE plugs are compatible with those of the STECK brand, which is the best known in the Brazilian market.

This type of connection, also called a plug-in connection, reduces the risk of accidents due to short circuits, electrical shocks or phase inversion that can cause equipment to burn.

Potência Solicitada (kva)	Corrente Elétrica Máxima (A)	Cabo (Tipo PP)	Tomada (Tipo Industrial - Fêmea - Terra 6hs)
0 a 22	32	6 mm	32 A
23 a 42	61	16 mm	63 A
Acima de 43	A distribuição elétrica estudada pontualmente.		Ponta Viva

According to Regulatory Norm NR-10 (art. 10.5.1, items “a” and “c”), this is the procedure to be followed when energizing distribution boards installed in temporary electrical installations. Before energizing the stand, the main circuit breaker must be turned off. After checking that the circuit breaker is turned off, take a voltage test on the stand’s general switchboard and on the other distribution circuits, regardless of the connection provided by the pavilion in the stand (Steck or 3-pin plug). This test is common and normative as mentioned above in the articles of NR-10, this is done so that no type of problem occurs when the stand is energized, which can cause equipment burnout and possible accidents to the people involved in the building process. Therefore, it is the contractor's responsibility to take a voltage test on the main switchboards before energizing the stand.



**ELECTRIC GROUNDING OF EACH STAND IS MANDATORY ACCORDING TO NR 3410.
São Paulo Expo only provides the electric point with the female steck.**

The electrical distribution, switchboard and sockets are the responsibility of the exhibitor.

3.22 ELECTRICAL APPLIANCES

Electrical appliances are widely used for stands’ building and taking down. Direct contact with electrical materials can cause serious or fatal injuries. To avoid any accidents, due attention must be given to safety in the use of electrical energy.

Here are some basic safety measures for using electricity:

- Check all electrical appliances before use. Repair or replace damaged or defective parts;
- If the electrical equipment protection device (fuse or circuit breaker) shows any failure, it is necessary to immediately check the problem and correct it before using the equipment again;
- All sockets and plugs must be suitable and electrical cable connections must be correctly protected;
- Avoid overloading electrical outlets;
- All electrical work must be done by an electrician.

3.23 USE OF ELECTRICAL TRANSFORMERS

The electrical transformer's load and consumption must be informed instead of the equipment's load. It must be compatible with the circuit breaker used in the stand's main switchboard and its peak current cannot exceed the capacity of the bus circuit breaker (120A).

If the transformer has a peak current greater than 120A, contact the technician responsible for the São Paulo Expo pavilion via email operacoessp@glbr.com.br

3.24 EQUIPMENT AND ENERGY TESTING

From **September 11th, from 10:00 am**, the pavilion's electrical energy will be turned on for testing the equipment. After the end, the supply will be made available regularly during the exhibition days, according to the opening and closing times.

3.25 USE OF PPE AND CPE

According to regulatory rule no. 6 of the Ministry of Labor and Social Security, the Organizer determines mandatory the use of PPE – Personal Protective Equipment and CPE – Collective Protective Equipment, specific to each function. According to Art. 157 of the CLT is up to the companies:

Some PPC examples:

- Safety signs;
- Protection for moving parts of machinery and equipment;
- Stairs railings;
- Chapel combustion gas, etc.

I. Complying with and enforcing safety and occupational health standards;

II. Guide the employee, through service orders, on the precautions to be taken to avoid accidents at work or occupational diseases.

People under 18 years old are not allowed to access the halls during building and takedown periods even if accompanied by a legal guardian.

Collective Protection Equipment - EPC is any device, system, fixed or mobile that has as purpose to preserve workers, users, and third parties' physical integrity and health.

During electrical installations services execution, and in its surroundings, collective protection equipment must be foreseen and adopted.

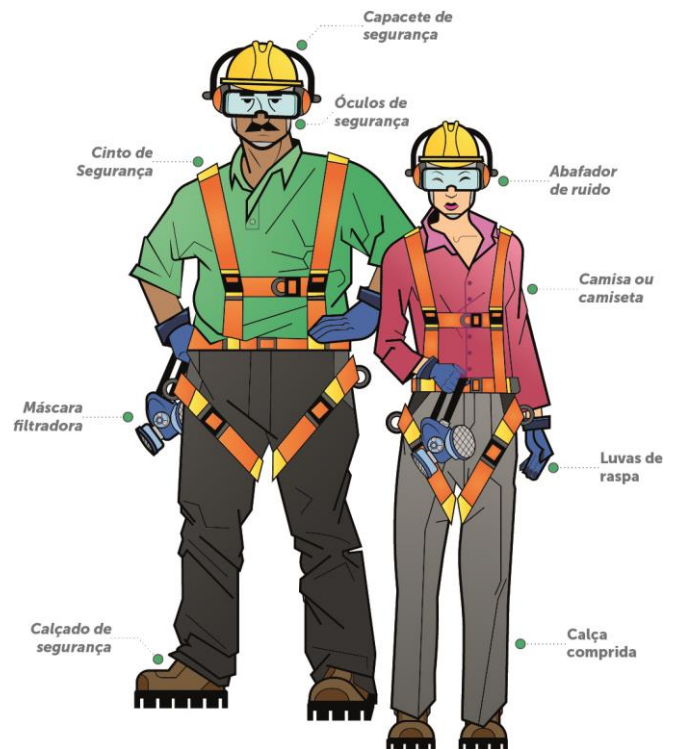

The use of sandals, slippers, clogs or any type of open shoe inside the exhibition park will not be allowed, as well as people wearing shorts, skirts, capri pants, tank tops or shirtless during building and takedown period.

*Large vehicles will not be allowed inside the pavilion from 8:00 p.m. on **September 10th** as well as during the exhibition days .*



3.26 COMMON AREAS

The traffic ways, and neighboring stands cannot be used for placing materials, tools, garbage bags and products to be installed in the stand. The entire operation must be carried out exclusively within the limits of the exhibitor's stand.

If it is necessary to leave any material, temporarily, on the traffic ways, the contractor will have to leave a free area of 1 m wide for the traffic of trolleys and the quick passage for emergency equipment, rescue teams, help, fire brigades and firefighters.

3.27 AIR CONDITIONING

SÃO PAULO EXPO - EXHIBITION & CONVENTION CENTER has an air conditioning system. The use of air conditioning machines inside the stands will not be allowed.

3.28 FINAL DECORATION AND STAND'S CLEANING

The stand's final decoration will take place on **September 11th, from 2:01 p.m.** Sanding, painting, welding, sawing and/or any other assembly that produces dirt is prohibited after this time.

It is the responsibility of the exhibitor/contractor to leave the stand clean for the official opening.

3.29 INSTALLING RUNNER RUGS TO COMMON AREAS

The runner rugs (carpets) will be installed from **5:00 p.m. on September 11th**, and from this time onwards, the entry of any assembly or exhibition equipment must be done in such a way as not to damage the runner rugs already installed.

Any breakdown or damage caused to the carpets will be the entire responsibility of the exhibitor, who must reimburse the Fair Management for the amounts related to the replacement and reinstallation of the damaged carpet roll.

3.30 PRODUCTS ENTRY

All the products will be free to enter the fair's park. It is the exhibitor's sole responsibility to comply with all legal requirements related to procedures for sending products, equipment and/or materials. See item "**Legal Requirements**" – "**Tax Procedures**").

IMPORTANT: The Organizer is not responsible for checking the exhibitor's products and does not have any type of storage area in the fair's park to keep the exhibitor's products or equipment. It is the exhibitor's responsibility to make available the storage for its materials and belongings, in addition to leaving an employee responsible for receiving equipment and / or products.

The Organizer disclaims all liability for damages, losses, or thefts of any kind..

On September 11th, only the decoration of the stands and the entry of materials by hand or by pneumatic rubber tires trolleys will be allowed, by 10:00 p.m.

3.31 TAKEDOWN PERIOD

On **September 14th**, from **08:00 p.m.**, the exhibitor must remove all decoration material, products, and equipment from rental companies, such as TV, DVD, computers, furniture and their belongings.

We request exhibitors to always leave a company representative in the place during takedown for equipment/products removal. The Organizer cannot be responsible for any loss, damage or theft of any kind that may occur during takedown.

The Organizer is exempt from any responsibility for damage, breakdowns, or thefts of any kind.

ATTENTION: The Organizer does not store any material that is left behind after the takedown.

- Withdrawal of materials in hand: from **8:00 p.m.** on **September 14th**.
- Removal of materials on trolleys: **after the runner rugs removal**, around **9:00 p.m.** on **September 14th**.
- The stands takedown will start at **10:00 p.m.** on **September 14th**.
- Takedown closure (the space must be clean): by **4:00 p.m.** on **September 15th**.

3.32 TAKEDOWN CLOSURE

When takedown is finished (according to schedule described above), The leased area must be given back to the Organizer, cleaned and unobstructed, without any materials, whether from the exhibiting company or the contractors.

Materials, equipment, and products that may remain on in the pavilion after finishing the takedown period will be removed by the fair management, which will charge to the exhibitor the costs resulting from this operation and will also execute the Responsibility Term.

IMPORTANT: We ask all exhibitors who handle oil and/or paint during the event to clean and protect the pavilion floor before removing the equipment, in order to not soil the pavilion's floor.

Companies that do not adopt this measure may be fined according to the damage verified. It is very important to guide the responsible technician.

3.33 INFORMA MARKETS AND SUSTAINABILITY

Our goal is to be an increasingly sustainable business with a positive impact on our clients and on communities close to the places where the events are held. By the **FasterForward** program, we include sustainability in everything we do and use the good opportunities to help our customers and markets do the same.

The program is structured around 3 pillars – **Faster to Zero, Sustainability Inside and Impact Multiplier** – with ambitious commitments and a wide range of activities, approaching Informa's business operations, our brands and products, and our impact on the wider community.

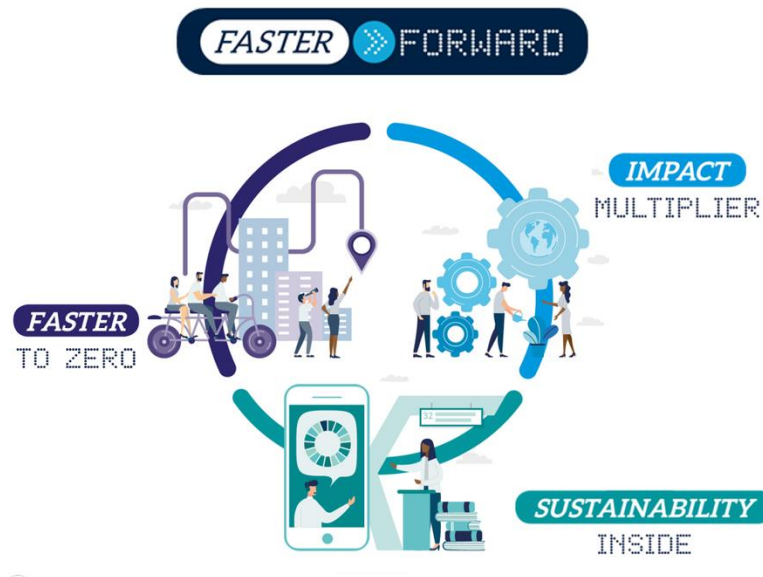

In the **Faster to Zero** pillar, one of our global goals is:

Halve the waste generated by our products and events by 2025.

And to achieve this goal, we launched the **Better Stands** program, which in turn has 2 goals: **eliminate the use of disposable structures**, replacing them with reusable structures, and **zero waste generation**.



We want to show that reusable stands can be better and create an even more relevant experience at our events, and we invite you, exhibitors, and contractors, to join us towards the future of events in Brazil and in the world, providing more sustainability for everyone and for the environment.

3.33.1 SOME IMPORTANT INFORMATION

Why are we asking exhibitors to stop building disposable stands?

Disposable stands create considerable environmental and safety issues on site due to the amount of waste generated, increased risks due to less safe construction practices and the toxic impact of the raw materials used in the stands. Finishing quality is also often affected due to work time pressures (building and takedown).

What is a disposable stand?

Its structure is usually built using materials that cannot be reused or recycled after the event, thus being used only once and then demolished and discarded, generating a huge amount of waste.

What is a reusable (non-disposable) stand?

A reusable (non-disposable) stand is constructed using materials designed to be used repeatedly. There are almost endless variations of multi-use brackets to suit every size and expected looks and as the cost of these brackets is often less than for disposable brackets this helps to reduce expenses and it turns into a better investment.

What is a prefab stand?

A prefabricated stand is one that arrives at the event in parts ready to be assembled, reducing the need for work on site. At the end of the event, the stand is disassembled into pieces and stored for reuse in other events.

Benefits of reusable and prefab stand:

- Reduces material waste and environmental impact;
- Reduces time of construction, building and takedown;
- Reduces project and construction cost;
- Increases safety for exhibitors, contractors and visitors;
- Makes it possible to invest in higher quality and more durable stands.

My stand is made of wood – isn't that already recyclable?

Most disposable stands built at events are constructed from MDF which cannot be recycled and when it is cut it releases clouds of carcinogenic dust particles.

Once used, MDF can only be disposed of in landfills or incinerated and therefore does not meet Better Stands requirements.

However, some prefab stands can be made from wood stock panels which are reusable and would therefore meet the new regulations. It is important that the contractor sends details of the materials being used to clarify this point.

3.33.2 GOOD SUSTAINABILITY PRACTICES IN EVENTS ORGANIZED AND PROMOTED BY INFORMA MARKETS.

Here they are some recommendations for you, exhibitors, to match your stand to the Better Stands program criteria.

Recommendable:

- All major elements as walls, arches, counters, etc. are constructed from reusable materials, e.g., system construction or stock panels;
- The stand structure must be prefabricated and ready for on-site building;
- Final adjustments to prefabricated parts for fitting purposes are allowed;
- Final coating in TVOC (Volatile Organic Solvent Content) paints acceptable for repairing purposes only;
- Flat floors and system floors must be cut to size before entering the site and be recyclable and/or reusable;
- The use of led lighting;
- The use of recycled carpet, vinyl flooring and other floor coverings.

Non-recommendable:

- The use of single MDF panels or similar raw materials designed to be cut on site;
- The use of 'other' raw materials to build major structural elements, as walls, arches, flooring systems, counters, etc., which are not intended to be reused or recycled after use;
- Construction of any stand's component from single-use materials;
- Build from scratch in the location of any central element of the stand;
- The use of incandescent light bulbs;
- The use of non-recycled carpet, vinyl flooring and other floor coverings.

By following these tips, you can be certain that your stand and brand will be allies in ensuring good sustainability practices, increasing audience engagement and at the same time your product and/or service will be much more valued by the market.

3.33.3 ABF SUSTAINABLE STAND AWARD

With the aim of valuing the sustainable practices of the exhibiting companies, Informa Markets, organizer, and promoter of Future Print 2023, will hold the 2023 Sustainable Stand Award, which will publicize and reward the brands with the most sustainable stands.

To participate, the exhibiting company must read and agree with all the information contained on the event page <https://www.concreteshow.com.br/pt/estande-sustentavel.html> and, at the end, fill in the REGISTRATION INFORMATION and the QUESTIONNAIRE.

Please note that participation is free and voluntary.

Among the possible evaluations that will be made throughout the event, we highlight the ones listed below, as a basis for the exhibiting company to have as a guideline for sending prior information on construction/building the stand:

- Quantity/percentage of material reused from other events for building the stand;
- Quantity/percentage of recyclable material used for building the stand;
- Number of trips that will be necessary to transport the equipment necessary for building and takedown the stand;
- What will be the type and amount of lighting used in the stand and whether there will be a container to collect the lighting;
- If there will be the neutralization of carbon generated at the event and if the company already has some kind of carbon neutralization in its activities;
- If the company has any environmental projects. If so, what are they?
- If the company has any certification or awards related to the ESG theme;
- Whether a refrigeration system (air conditioning) will be used in the stand;
- Which material was used to make gifts and bags;
- If the stand has a waste management system and if there will be waste collectors. If so, which ones.
- What means of transport will be used by the exhibitor's team to get to the event;
- Whether there will be accessibility mechanisms at the stand for different audiences.

References:

Better Stands

<https://portal.informa.com/sites/informa-markets/SitePage/177216/im-better-stands>
<https://www.youtube.com/watch?v=i0e6tLueeww>

Faster Forward

<https://www.informa.com/sustainability/faster-forward/>
<https://www.informamarkets.com/pt/sustentabilidade.html>

4 REGULATORY STANDARDS

The Regulatory Standards – (NR) are used to regulate/ instruct about the mandatory procedures related to work health and safety in Brazil. The Regulatory Standards from Chapter V, Title II, from the Working Consolidation Laws (CLT), related to the Job's Health and Safety, were approved by the Ordinance N° 3.214, from 08 June 1978 and are mandatory to be followed by all Brazilian companies following the CLT legislation.

During the building and takedown periods, the requirements contained in the NR must be met, among others:

NR 06 – Personal Protective Equipment

NR 10 – Security in Facilities and Services in Electricity

NR 11 – Transport, Handling, Storage and Material Handling

NR 18 – Conditions and Working Environment in the Construction Industry

NR 35 – Working at Height

For all the heights and electricity work, the training specified in the correspondent NRs will be required to allow the respective work. The promoter will develop a system for identifying the contractors' employees by using an identifier bracelet for each type of work, which must be worn throughout the building and takedown period.

Training certificates for the use of crane equipment (NR 11), aerial work platforms (NR 18), must be checked with the service provider hired by the contractor and exhibitor, upon request by the organizer.

For further information and to learn about all standards, visit: <https://www.gov.br/trabalho-e-previdencia/pt-br/composicao/orgaos-especificos/secretaria-de-trabalho/inspecao/seguranca-e-saude-no-trabalho/ctpp-nrs/normas-regulamentadoras-nrs>

4.1 NR-12 – HEALTH AND SAFETY IN MACHINERY AND EQUIPMENTS OPERATION

As explained in the Legal Requirements Chapter of this Manual in the item “INSPECTION OF THE MINISTRY OF LABOR AND SOCIAL SECURITY” Exhibitor, Promoter, contractors, and service providers must comply with all Regulatory Standards, Conventions, Decrees, Normative Instructions, Laws, and Ordinances applied to Occupational Safety and Health.

Especially regarding Safety at Work with Machines and Equipment related to this event, we ask you to observe the specificities of **NR-12 – SAFETY AT WORK IN MACHINERY AND EQUIPMENT**.

The full content of all legislation related to the Ministry of Labor and Social Security can be accessed at the following link: <https://www.gov.br/trabalho-e-previdencia/pt-br/assuntos/legislacao-trabalho>

In addition to the Regulatory Norms of the Ministry of Labor and Social Security, the Exhibitor must observe the fundamental concepts and general principles of design, related to Machinery Safety, established by “ABNT” in accordance with the Brazilian Committee of Machinery and Mechanical Equipment and the Sectorial Committee MERCOSUR of Machinery and Mechanical Equipment.

Since June 11, 2010, the manufacture, import and sale of machinery and equipment that have squirrel cage rotor induction electric motors between 1 hp and 250 hp, which do not meet the high-performance requirements, has been prohibited.

The labeling of engines with the above characteristics is mandatory and must obligatorily meet INMETRO conformity assessment requirements.

It is important to point out that the use of machines and equipment that do not meet INMETRO requirements will be subject to inspection, as well as a fine or seizure.

The ordinances that regulate the issue of electric motors are:

- **Regulation INMETRO n° 243, September 4th , 2009.**
<http://www.inmetro.gov.br/legislacao/rtac/pdf/RTAC001485.pdf>
- **Regulation n° 488, December 8th de 08, 2010.**
<http://www.inmetro.gov.br/legislacao/rtac/pdf/RTAC001643.pdf>

We warn you that the labor inspectors will carry out, during the fair, inspections on the machines and equipment on display.

If it is necessary to remove safety devices to better display the products, we suggest that the device is also displayed and that it is highlighted with warnings to visitors that the machine is without them, even if it is not put into operation under these conditions.

4.2 USE OF LADDERS

It is common during the building and takedown period to use ladders inside the pavilion. Some precautions are necessary to keep all the workers safe:

- Choose the right type of ladder for the job;
- Use only good quality ladders in perfect condition;
- Keep the three balance points before starting to use;
- If necessary, ask someone for help to protect and provide the necessary assistance;
- Use the ladder for light and short-term work. Do not overload the ladder.
- Do not work on the ladder's step when it is above 2.00 m in height. If necessary, it is mandatory to use the protection belt;
- Do not place the ladder on uneven, inclined surfaces or on loose materials;
- Provide information, correct instructions, training and supervision for ladder's users;
- The scaffolding work floor must be fully covered, non-slip, level and secured or locked safely and resistantly;
- Scaffolding must have a guardrail and baseboard system, including the headboards, around the entire perimeter, except for the side facing the work;
- Access to the scaffolding must be done safely using a ladder embedded in its structure;
- It is forbidden to move the scaffolding structures with workers on them;
- Scaffolding towers cannot exceed, in height, four times the smallest dimension of the support base, if they are not guyed;
- Scaffolding casters must be equipped with locks, in order to avoid accidental displacements.

4.3 BALLOONS AND DRONES

Balloons and drones are forbidden to overfly the exhibition park due to the risk of falling, fire, and crash.

If it happens, the infractor company will be immediately fined by the Organizer.

5 ADDITIONAL INFORMATION

5.1 SECURITY AT THE PAVILION

The security service will be available during the full period of building, exhibition days and takedown period, **in the event's common areas.**

It is the responsibility of each exhibitor to provide security for their stand, objects and equipment exposed during building, exhibition days and takedown.

5.2 MEDICAL ASSISTANCE

The emergency medical service will be working at times compatible with the periods of building, exhibition days and takedown established in this manual.



If you need to keep working after the hours set in this manual, there will be a charge. The responsible person must go to CAEX to request and make the immediate payment.

ATTENTION: Delivering products or staying in the pavilion after the time announced by the event's Organization will only be possible with prior authorization from the Operational Team, provided that the medical service is available on site.

5.3 TELEPHONE AND INTERNET

For events held at São Paulo Expo, Hipernet provides direct line and internet cable rental services configured with the requested speed. The rental period will be counted from the date of installation. Internal cabling and router installation are the sole responsibility of the exhibitor.

Phone number: +55 11 3077-5500

Website: feirasspo@hthnet.net

IMPORTANT: We inform you that there will be no wireless access (wi-fi) in the São Paulo Expo pavilion.

5.4 INSURANCE

It is **mandatory** for the exhibitor to hire specific **Insurance for Different Risks - DR and Civil Liability - CR**, which offer sufficient coverage for the risks involved during building and takedown of the stand and the exhibition days. The contact of the official company will be included in the **Official Suppliers List** up to 60 days before the event starts, however, we reiterate that the exhibitor is free to contract the most convenient insurance company for its own.

Coverage must be contracted by insured amount sufficient to cover losses resulting from damage to third parties, personal and material, or to the Exhibition Pavilions and resulting from malfunctions and qualified thefts of the respective displayed material.

It is exclusively up to the exhibitor to provide their own insurance (civil liability, several risks, and personal injuries) during the building, the exhibition days, and the takedown period. The Organizer will not be responsible for any damages or costs due to occurrences in the stands related to products, materials, contracted companies, assembly companies, transportation companies, people or of any other kind.

It is important to check, in the policy, the insurance coverage and the period of validity, which must count from the 1st day of building until the last day of takedown.

To hire an insurance: <https://vendas.seguroexpositor.com/plataformas/informa-markets/feiras-e-eventos>

IMPORTANT: The Organizer is not responsible for any thefts or robberies that may occur on the fairgrounds.

5.5 INTERNAL LOGISTICS SERVICE

The contact of the official company will be included in the **Official Suppliers List** up to 60 days before the event starts.

Accredited companies do not have the exclusive right to provide logistics services. Exhibitors are free to choose to hire another company of their choice.

The exhibitor is responsible for any damage caused by a third-party transport company and the movement of this equipment inside the pavilion (e.g., tire marks, oil stains on the floor, accidents, and damage to the pavilion structure).

5.6 CUSTOMS CLEARANCE AND FREIGHT FORWARDER

Arrange in advance for shipment and clearance of goods to ensure the arrival of goods and equipment for the exhibition. Contact the specialized Cargo Agents to receive shipping instructions.

Equipment, machinery, and other materials for exhibition may be shipped temporarily, under taxes payment exemption, and they may be re-exported or nationalized if they are sold.

Deadline dates:

- Sea shipments must arrive at the Port of Santos up to 30 days before the date of delivery at the stand

- Air shipments must arrive at Guarulhos Airport up to 15 days before the delivery date.

Before shipment, the Cargo Agent must receive a copy of all documents, for verification.

For hiring import services, for temporary/definitive admission of goods or samples, the exhibitor may hire the Official company.

The contact will be published on the Web Portal 60 days before the exhibition starts.

IMPORTANT: The exhibitor is free to choose to hire shipping, customs clearance and/or goods transit.

5.7 CO-EXHIBITORS ATTENDANCE

The Co-Exhibitor Participation Form should be requested from the Commercial Department of the fair. After filling it out, the document must be sent to adriana.zimmermann@informa.com until August 09, 2023, for analysis.

The participation of the co-exhibitor will only be possible with the express authorization of the Promoter, as long as it is in conformity with the segment the fair is aimed at.

After approval a Co-Exhibitor Participation Fee will be generated, as per item 8.5 of the Participation Contract and Municipal Tax of the City of São Paulo as per law Nº 13.477/02 (TFE).

It will be mandatory for the exhibitor to present in the project the division of its respective area.

When the participation is released, the main exhibitor will be responsible for the payment of the City Tax of each new co-exhibitor authorized to participate in the event, due to the transfer to the City of São Paulo.

All and any material made available to the co-exhibitor will always be sent to the main exhibitor, according to the participation contract, which will deal directly with each co-exhibitor.

6 EXHIBITION DAYS

Exhibitors must keep at least one of his employees in the stand, who must be able to provide information about the products on display. It is mandatory to have a responsible employee at the stand at least 30 minutes before the exhibition's opening.

You will not be allowed to close the stands before the exhibition's closure, even on the last day.

The lighting will be on during the exhibition opening hours and the exhibitor is responsible for turning off the main power switch of your stand, at the end of each day.

6.1 PROMOTIONAL DISTRIBUTION AND BRAND'S PROMOTION

It is forbidden for exhibitors to locate staff outside the stand boundaries for sale or flyers distribution, freebies and so on.

Exhibitors will be allowed to distribute gifts, samples, brochures, and catalogues exclusively inside the stand, except for non-participating companies that have no connection to the exhibitor.

If it is essential to the exhibitor to display products, equipment and services which are not manufactured or exclusively related to their product line, they should send a written request to the Organizers for approval, who may or may not approve its displaying.

It will not be allowed:

- Advertising, promotion or marketing of any other promoter of events inside the pavilion;
- Products and/or exhibiting companies NON-Exhibitors/Co-Exhibitors or Brands previously approved by the Organizer as they are due commercial representation. (according to item 6.7 of this Manual)
- Displaying brands and soft drinks brands in well located places.

Exhibitors who do not comply with this determination will have their material confiscated by the Security Department and may get it back only after the exhibition closes. The Organizers may also, at any time, prohibit the operation of the stand.

Selling products or services to the exhibition visitors during the event is prohibited, except for exhibitors operating in the food court.

6.2 DIVERSITY AND HARASSMENT

Informa Markets, as the promoter and organizer of the Brazil Windpower event, totally rejects any kind of discrimination, like every employee selection that adopts discriminatory criteria regarding to gender, origin, race, skin color, marital status, family situation, disability, age, sexual orientation, physical appearance, among others. We strongly encourage our exhibitors to celebrate diversity in every way when hiring professionals to work at the Event.

We also recommend that exhibitors and agencies contracted by them to select and hire the staff that will assist the stand on the exhibition days, pay attention to the clothes the team must wear, in order to avoid any kind of embarrassment or harassment that, in most situations, are experienced by women. Remember that the staff will represent the brand and values expressed by the company.

6.3 MACHINERY AND VEHICLES EXHIBITION INSIDE THE STAND

Equipment and/or large vehicles that will be displayed during the event must be listed and previously informed to the Organizer for approval along with the information about the project. This information is important to control truck access to the pavilion/loading and unloading area and ensure that equipment is placed in the respective areas in a timely manner.

It is also mandatory to send this demonstration project, covering security and acoustic insulation issues when necessary.

For all motor vehicles that will be on display, it is mandatory that the fuel tanks are below the reserve line to avoid large amounts of flammable liquid in a closed place.

The Operational Team may, at any time, request inspection of the vehicle's fuel level.

- The exhibition/demonstration of any used machinery and/or equipment is prohibited. All the machinery or equipment must be new, from the factory and unused. The Organizers, at any time, will notify the exhibiting company and will require the removal or coverage of the equipment mentioned, and will take the appropriate measures at the expense of the exhibitor.
- The demonstration of any equipment, product, structure or element that poses a risk to people, or that produces a high level of noise or vibration that could disturb the operations of neighboring stands, will be suspended by the Event Organization.

The noise limit allowed during the event will be 70 DECIBELS.

6.4 EVENTS HELD INSIDE THE STANDS

It is strictly prohibited to conduct some events such as:

- Pyrotechnic shows with the use of smoke or dirigibles;
- Presentation of live models half naked or wearing loincloth;
- Pets* of any kind or size, including birds to stand's decoration or to complement the demonstration of products;
- Flying drones inside the pavilion.

***You must previously ask to the Organization about the possibility of keeping animals in the stand, because it is necessary to follow the determinations of the CFMV (Federal Council of Veterinary Medicine) regardless of the animals' health conditions and quality of life, in order to ensure their safety and well-being.**

6.5 TICKETS

BRAZIL WINDPOWER EXHIBITION has a ticket office. The price for advance purchase of tickets through the event's website (<https://www.brazilwindpower.com.br>) will be announced soon.

IMPORTANT: Since the exhibition is a business event, entrance is not allowed for people wearing shorts, a tank top and/or flip-flops, as well as for people under 18 years old, even if they are with their guardians.

6.6 STAND'S SUPPLY, MAINTENANCE AND CLEANING

Products supply and/or stand maintenance services must be done **by 9:00 am** on each day of the exhibition or after its end.

Access must be made through the loading and unloading sector of the pavilion.

The contractor must request at most **2 (two) credentials** for any maintenance services during the event. The employees who will provide the service must show up at CAEX on the last day of the building period and exchange the credentials.

If the exhibitor needs emergency maintenance, they must go to the CAEX - Exhibitor Service Center and request authorization, the approval criterion being the sole and exclusive responsibility of the Fair Management.

6.7 MERCHANDISING

It will be considered merchandising any advertisement promoted outside the stand. The merchandising products aim to increase the exhibitor's visibility and publicizing.

To learn more about the merchandising tools available for the event, please contact our Sales team:

Adriana Guidi – E-mail: adriana.guidi@informa.com

Sergio Zacarias – Phone number: (11) 4632-0589, E-mail: sergio.zacarias@informa.com

Camila Fernandes – Phone number: (11) 99526-1199, E-mail: camila.Fernandes@informa.com

Fabio Oddone – Phone number: +55 (11) 93273-8796, E-mail: fabio.oddone@informa.com

Bianca Vaz – Phone number: +55 (11) 9 8912-9959, E-mail: bianca.vaz@informa.com

It will not be allowed to install any material without a signed and paid merchandising contract by the exhibitor.

6.8 COMMERCIAL REPRESENTATION

When the exhibitor is a commercial representation company, trading company, holding company, member of a business group or when it has associated companies, it will be allowed to present products from other brands as long as the exhibitor previously provides the Organizer with the list of companies, along with proof of existing exclusive relationship.

NOTE: This approval is not related to the authorization for Other Brands Promotion. Therefore, you cannot use them on the stand's fronts and walls as a promotion, which is allowed only to the company's brand that is linked to the contract with the Organizer.

6.9 SOUND AND BACKGROUND MUSIC

All sound produced on the stands by audio-visual devices, recorders, radios, or any other equipment must not exceed the voice's normal volume or 70 decibels.

The use of any amplifying equipment for sales or promotion messages is prohibited.

In case the exhibitor does not comply with these rules, the following measures will be taken by the Organizers:

✓ On the first violation: a verbal request will be made to establish the allowed sound volume;

✓ On the second violation: the same request will be made by letter by the Organizers.

Non-compliance with reducing sound levels requests will result in stand power off without prior notice, and removal of the equipment for undetermined time and subject to a fine and charge as a penalty fee.

For lectures, presentations, etc., it is necessary to use closed rooms, auditoriums, etc.

According to Law 9610/98, which regulates music royalties, the exhibiting company that uses lounge music on its stand, even playing public radio transmissions, must pay a specific charge, using the specific form, provided by ECAD (Central Collection and Distribution Office for Artists' Royalties).

ECAD – SP

171, Paulista Ave., 3rd floor CEP: 01311-000 – São Paulo – SP

ZIP CODE: 01311-000 – São Paulo – SP

Contact Soliane: +55 (11) 3287-6722 – Ext. 1132

Contact Ana Claudia: +55 (11) 3287-6722 – Ext. 1146

Fac-simile: +55 (11) 3285-6790

E-mail: eventossp@ecad.org.br

Website: www.ecad.org.br

ATTENTION: The exhibiting company that intends to promote any concerts, live music, presentations, etc., must previously consult the Fair Management to get authorization.

6.10 PRIZES PROMOTIONAL DISTRIBUTION AND RAFFLES

The operation, issuing authorizations and supervision of activities related to the free distribution of prizes made by raffles, gift certificates, contests or similar are the responsibility of Caixa Econômica Federal, except when Caixa Econômica Federal itself or any other financial institution is interested party. In these cases, the authority to analyze and authorize the requests rests with SEAE – Secretariat for Economic Monitoring of the Ministry of Finance.

For further information, access <https://www.caixa.gov.br/empresa/promocoos-sorteios/Paginas/default.aspx>

The necessary authorizations and documents are the sole responsibility of the Exhibitor.

IMPORTANT: The Organizer has no relationship with the competent bodies determining standards for the practice of distributing prizes and raffles.

6.11 USE OF SUBSTANCES

Exhibitors who offer alcoholic drinks must comply with Law 14,592/2011 that prohibits the sale, offer, supply, delivery, and the consumption of alcoholic drinks, even if they are for free, to minors under 18 (eighteen) years old. The consumption of alcoholic beverages at the Event, when permitted, must be appropriate and moderate. Anyone under the influence of any of these substances will be immediately removed by the Organizers and permanently kept away from the location during building, exhibition days and takedown period.

Therefore, all exhibitors, by themselves or their legal representatives, agents, or employees, undertake the duty of care, protection and vigilance and must:

- (I) Post, in enough amount to ensure its visibility throughout the space, a notice prohibiting the sale, supply, delivery and consumption of alcoholic beverages, even if free of charge, to minors under 18 (eighteen) years old, in size and place of wide visibility, **with express reference to this law and to article 243 of Federal Law No. 8.069, of July 13, 1990**, containing the following warning:
“ALCOHOLIC BEVERAGE CAN CAUSE CHEMICAL DEPENDENCE AND, IN EXCESS, CAUSES SERIOUS HEALTH PROBLEMS”;
- (II) Require an official ID, in order to prove the age of majority of the person interested in consuming alcoholic beverages and, in case of refusal, they must not supply the product.

- (III) Do not allow the consumption of alcoholic beverages by people under 18 (eighteen) years old inside the stands.
- (IV) Make alcoholic beverages available in specific places or stands, different from the other products on display, posting the signage referred to in item (i) above in the same space.



If you have any questions, the whole content of this legislation can be consulted at the link:

<https://www.alcoolparamenoreseproibido.sp.gov.br/wp-content/uploads/2019/08/pl698a11-parcial.pdf>

6.12 PROHIBITED ACTIVITIES

The following activities are prohibited:



- Use of flames in the pavilion;
- Electric generator and radioactive material;
- Storing gasoline, kerosene, diesel or other flammable liquids inside the pavilion, even if just temporarily;
- Explosives, pyrophoric material;
- High speed or the reckless use of vehicles or equipment, including forklifts;
- Underage workers (18 years old) during building and takedown period;
- Welding service (only under authorization from the Organizers);
- Spray or air-compressed painting service (only under authorization from the Organizers);
- Products classified as dangerous, including toxic, irritating, corrosive, harmful or oxidizing materials (except for domestic cleaning material);
- Equipment that may cause discomfort due to the odor, or unpleasant noise or even strobe lights;
- Popcorn machine cart;
- Selling or delivering drinks in glass containers

6.13 FIRE EXTINGUISHERS

It is mandatory for exhibitors to keep fire extinguishers in their stands in compliance with the following rules: NR 23 (fire protection), NBR 14,276/1999 (fire and panic brigade) and decree 46,072/2001 (fire protection). Non-compliance with this rule will result in a fine that will be charged during the exhibition days.

The contractors must keep 1 (one) fire extinguisher in the stand every 25 sqm during the building, exhibition days and takedown period. Its charge must be compatible with the products on display and with the materials used for building the stand, and correctly signaled. We recommend chemical powder extinguishers, CO² or ABC 4 kg weigh.

CLASS	MATERIAL
A	Materials that burn on the surface and in depth and leave residues as paper, wood, fabrics, fibers, etc.  such

B	Flammable products such as gasoline, thinner, diesel, etc.	
C	Energized equipment such as electric motors, machines, etc.	

6.14 COMBUSTION ENGINES

Internal combustion engines will not be allowed inside the pavilion.

The use of any explosive, non-liquefied, toxic, and combustible gases or LPG and helium gas cylinders inside the pavilion is prohibited.

7 LEGAL REQUIREMENTS

The exhibitor has sole responsibility in complying with the legal requirements related to following:

- Taxes related to Federal Service, Revenue Service, Municipality, City Hall, Social Security;
- Ministry of work;
- Central Collection and Distribution Office (ECAD);
- COVISA (Health Vigilance Coordination);
- National Sanitary Vigilance Agency (ANVISA)
- ANATEL – National Telecommunications Agency
- Federal Inspection Service (SIF)

7.1 TAX PROCEDURES



Do not issue the invoices qualifying the Organizer (Informa Exhibitions) as the final receiver. There is not this kind of operation on The ICMS regulation.

7.1.1 INVOICE FOR SHIPPING AND RETURN OF GOODS

It is the Exhibitor's responsibility to comply with the legal requirements regarding the procedures for shipping and returning goods, equipment, products, tools, etc.

7.1.2 SIMPLE REMITTANCE INVOICE

The Exhibitor must issue a Simple Remittance Invoice, in its own name (sender establishment).

The header of the Invoice must be filled in with all the information (Company Name, Address, CNPJ and State Registration) of the Exhibitor (Sender Establishment). It is the same for shipments made by branches.

Third-party shipments must be covered by the Exhibitor's Invoice. The body of the Invoice must list all goods, equipment, products, utensils, etc. with its real value and the following expressions:

*“These goods are intended for **Brazil Windpower exhibition**, to be held from September 12 to 14, 2023, at São Paulo Expo, Rodovia dos Imigrantes, S/N, KM 1,5, CEP 04329-900, São Paulo, and must return within a maximum period of 60 days”.*

“Exit under ICMS exemption, in accordance with Article 33rd, Annex I of RICMS’2000.”

In case of an industrial establishment must also include the expression below:

“Exit under IPI exemption, in accordance with Article 40 - Item II of RIPI/98.”

The Organizer, through its Security company, **may request the Simple Remittance Invoice when the products enter the Exhibition Pavilion.**

7.1.3 PRODUCTS RETURN INVOICE

The Exhibitor must issue an Entry Invoice in its own name, mentioning the number and date of the Simple Remittance Invoice, including the following expressions:

*“Return from exhibition - **Brazil Windpower** exhibition, to be held from September 12 to 14, 2023, at São Paulo Expo, Rodovia dos Imigrantes, S/N, KM 1,5, CEP 04329-900, São Paulo, from the Simple Remittance Invoice (number and date)”.*

“Return exempt from ICMS in accordance with Article 33, Annex I, of RICMS’2000.”

In case of an industrial establishment, it must also include the expression below:

“Return under IPI suspension, in accordance with Article 40, Item II, of RIPI/98.”

7.2 IMPORTS

7.2.1 ICMS

The products or goods importation from foreign countries under the Temporary Admission Scheme benefits from the ICMS exemption, in total suspension of payment of federal taxes for importation, according to the deadlines and conditions established in federal legislation and when they are intended for:

- Fairs, exhibitions, congresses and other scientific or technical events;
- Fairs and exhibitions, commercial or industrial;
- Shows, exhibitions and other artistic or cultural events.

(RICMS-SP/2000, Annex I, art. 37, VI)

7.2.2 TEMPORARY GOODS ADMISSION FOR TRADESHOWS, EXHIBITIONS, CONGRESSES AND OTHER EVENTS (FEDERAL REVENUE SERVICE)

The temporary admission is a customs option that allows both foreign and Brazilian exhibitors who want to participate in fairs and events, to bring some products from other countries under total or partial exemption of import taxes payment.

This benefit is only valid when these goods importation is for participating in events of the following nature: cultural, artistic, scientific, commercial, and sporting, besides the goods transportation for rehearsals and tests, under the commitment to be re-exported and as long as it is regulated by the following rules: IN SRF No. 35/99, IN SRF No. 285/03 and IN SRF No. 611/06.

The procedures to be followed in the customs clearance, as the declaration to be used, depend exclusively on the final use of the goods and can be found online on Federal Revenue Service at: <http://idg.receita.fazenda.gov.br/orientacao/aduaneira/regimes-e-controles-especiais/regimes-aduaneiros-especiais/regime-de-importacao-comum-para-bagagens-1> (DECREE No. 6759, FEBRUARY 5, 2009. Customs Regulation - Article 136 – O).

FEDERAL REVENUE

CUSTOMER SERVICE - RECEITAFONE: 146

7.2.3 IPI (INDUSTRIALIZED PRODUCTS TAX)

Goods/products sent directly to exhibitions content similar goods and products, that are produced by the industry company, can have exemption of IPI tax according to Art.43, II of RIPI/2010 – Parecer Normativo CST number 242/1972.

For more information regarding Normative Instruction RFB No. 1.361/2013, arts. 3, caput, § 1, II, 4, 5, visit:

<http://normas.receita.fazenda.gov.br/sijut2consulta/link.action?idAto=42144&visao=anotado>

7.3 COVISA, ANVISA and SIF

Exhibitors are required by law to keep their products, goods, services, environments and processes subject to sanitary surveillance at all times in compliance with COVISA and ANVISA legislation, remembering that the stand in a fair or event is a temporary establishment for the exhibitor.

COVISA – (HEALTH SURVEILLANCE COORDINATION)

181, Santa Isabel St, Vila Buarque

ZIPCODE: 01221-010 – São Paulo –SP

Service Hours: 9 a.m. - 4 p.m., from Monday to Friday.

Phone Numbers: +55 (11) 3397-8278/ 3397-8279/ 3397-8280

http://www.prefeitura.sp.gov.br/cidade/secretarias/saude/vigilancia_em_saude/

ANVISA – AGÊNCIA NACIONAL DE VIGILÂNCIA SANITÁRIA (NATIONAL HEALTH SURVEILLANCE AGENCY)

Trecho 5, Área Especial 57

ZIP CODE: 71205-050

Brasília – DF

Service hours: 7:30 a.m. – 7h30 p.m., from Monday to Friday.

Phone: 0800 642-9782

<http://portal.anvisa.gov.br>

All products derived from animals which are under the responsibility of the Ministry of Agriculture, Livestock and Supply are registered and approved by S.I.F. aiming to guarantee products with sanitary and technological certification, respecting current national and international legislation.

SIF – FEDERAL INSPECTION SERVICE

Ministério da Agricultura, Pecuária e Abastecimento

(Ministry of Agriculture, Livestock and Supply)

Esplanada dos Ministérios - Bloco D - Brasília/DF – ZIP CODE: 70.043-900

Phone number: (+55 61) 3218-2828

Customers Service: 0800 704 1995

<http://www.agricultura.gov.br/assuntos/inspecao/produtos-animais/sif>

7.4 MINISTRY OF WORK INSPECTION

CONTACT: MINISTRY OF WORK

Alô Trabalho Customers: 158 (just for Brazil)

<http://portal.mte.gov.br>

7.4.1 MINISTRY OF WORK AUDITOR

Verifies compliance by companies with worker protection legislation, aiming to fight against informality in the labor market and ensure compliance with labor legislation.

http://portal.mte.gov.br/fisca_trab/

7.5 SOCIAL SECURITY

OUGPS (SOCIAL SECURITY OMBUDSMAN OFFICE)

Phone number - 135

PREVCartas (Postal Service): Mailbox 09714 - ZIPCODE 70001-970 - Brasília-DF

In-person customer service: Esplanada dos Ministérios, Bloco F, Edifício Anexo, Ala "A", 1º andar
From Monday to Friday, 8 a.m. – 6 p.m.

Website: www.previdencia.gov.br

ANNEX 1 – REFERENCE FOR KVA CALCULATION

EQUIPMENT	KVA
Commercial coffee machine 1700w/ 2700w/ 3000w/ 5000w	1,70/ 2,70/ 3/ 5
Residential coffee machine 600w/ 800w/ 1100w	0,60/ 0,80/ 1,10
Griddle 3000w	3,00
Griddle 6000w	6,00
Griddle 9500w	9,50
Draft Beer Equipment	0,50
DVD player	0,30
Oven 1000w	1,00
Oven 1750w	1,75
Oven 2400w	2,40
Oven 5000w	5,00
Oven 8000w	8,00
Microwave oven	1,20
Freezer	0,50
Frying Machine 2500w	2,50
Frying Machine 5000w	5,00
Refrigerator/ Mini Fridge	0,30
Printer	0,25
Dichroic lamp (Halogen)	0,05
Dichroic lamp (LED)	0,01
Fluorescent lamp PL 20w / 40w (with reactor)	0,03/ 0,05
Halogen lamp 300w / 500w	0,30/ 0,50
Fluorescent lamp HO 110w	0,22
Lamp HQI 150W + Reator	0,35
Incandescent lamp 100w	0,10
Mixed lamp 250w	0,25
Lamp PL 40w	0,05
Desktop	0,50
Laptop	0,03
Electric sandwich griller 3000w	3,00
Electric sandwich griller 6000w	6,00
Projector 150w/ 350w/ 500w	0,15/ 0,35/ 0,50

Bain-Marie warmer countertop 1000w	1,00
Halogen lamp spotlight 180w/ 300w/ 500w	0,18/ 0,30/ 0,50
HQI 150w lamp spotlight (with reator)	0,30
Spotlight (LED) 20w/ 30w/ 50w	0,02/ 0,03/ 0,05
Juice dispenser machine 300w	0,30
Television (average consumption)	0,30

ATTENTION: The kVA numbers above refer to consumption during the whole time of exhibition. The table above should be used only as a reference for calculating the consumption of common equipment. It is necessary to observe the technical manuals or the plate on the device's body, which contains the installation features.

The kVA used in your stand during the event will be checked and controlled by the company responsible for this area. If consumption exceeds the contracted amount, the exhibitor will receive a notification and charge during the event.

RESPONSIBILITY TERM FOR EXHIBITORS AND CONTRACTORS

Exhibitor: _____

Trading name: _____

CNPJ: _

Legal Representative: _

Contractor:

Stand number: _____

SQM: _____

Trading name:

CNPJ: _____

Legal Representative:

Provided services:

For the execution of this term, the parties consider that:

- (i) The Exhibitor entered into a Participation and Services contract with the Organizer – Informa Markets LTDA., whose object is the leasing of an area for **Brazil WindPower 2023** to be held between **September 12 to 14, 2023**;
- (ii) The Exhibitor undertakes to effectively comply with the specific conditions, general conditions and participation manual that make up the Agreement entered into with Informa Markets;
- (iii) The Exhibitor expressly declares that it is fully and unrestrictedly aware of the safety rules and measures that must be adopted by itself, its legal representatives or agents, and also by the contractors, suppliers, service providers, third parties and their employees;
- (iv) The Exhibitor is the sole and exclusive contracting party for the services of the Contractor, qualified above, and shall ensure the conservation of the area and the effective compliance with all rules and safety measures by the Contractor, being fully responsible for the services contracted, either with Informa or any third party;
- (v) The Contractor declares responsible for building the stand, for the material, the team and for any other contracted service provider during the stand's building until its takedown.

Having made the preliminary considerations above, the parties, Exhibitor and Contractor, hereby declare to be jointly and severally liable to INFORMA MARKETS LTDA., located at Av. Doutora Ruth Cardoso, 7221, 22nd floor, São Paulo, SP, and enrolled with the CNPJ/MF under No. 01.914.765/0001-08:

- (i) For the conservation of the area where the services will be carried out, undertaking to return it in the same way in which it was found, free and unoccupied of people, things and any materials;
- (ii) For building the stand in accordance with the rules, standards and contractual requirements stipulated in the Exhibitor Manual and also by all those expressed in current legislation;
- (iii) For effective compliance with the rules and safety and health measures at work in order to protect and prevent risks and damage to the life and health of workers, also adopting all the necessary measures for their inspection;
- (iv) For compliance with all Regulatory Norms (NRs) applicable to events, which are legal norms incorporated into Brazilian legislation, ensuring that all its employees and/or contractors are legally qualified in accordance with said norms;
- (v) For any damage that may be caused, directly or indirectly, to the Pavilion, service providers, employees or any third parties.

First Paragraph: In case of non-compliance with item (i) above, the Contractor will pay the Organizer a non-compensatory fine of BRL 2,000.00 (two thousand reais), without loss to the determination and compensation of any damages that may occur in the buildings, facilities, equipment, and accessories.

Second Paragraph: The parties, Exhibitor and Contractor, will be jointly and severally liable, by themselves, by their legal representatives or by their agents, for any damages that they may cause during the services provision, whether material or moral, civil or criminal.

São Paulo, (month) (day), (year).

"Agreed":

Exhibitor's name

Contractor's name

Exhibitor's signature

Contractor's signature

FOR THE ORGANIZER USE:

We certify that the good was returned in ____/____/2023, in the following conditions:

- In perfect conditions
- missing parts or accessories
- Present with defects:
- Other: